

CAD FILE:

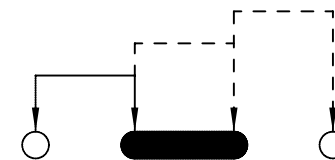

SCHEMATIC (NON-SHORTING)

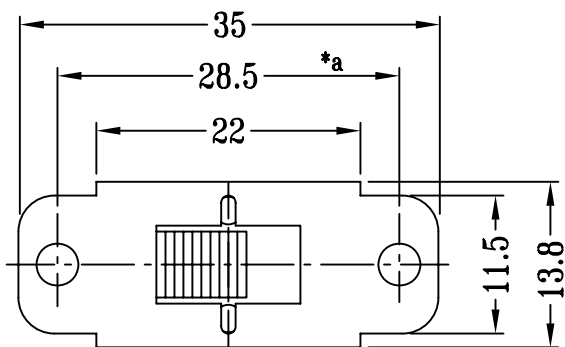
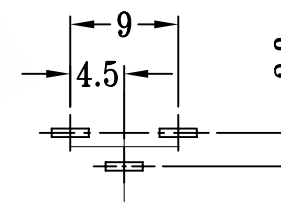
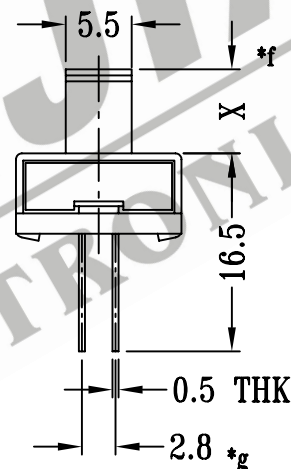
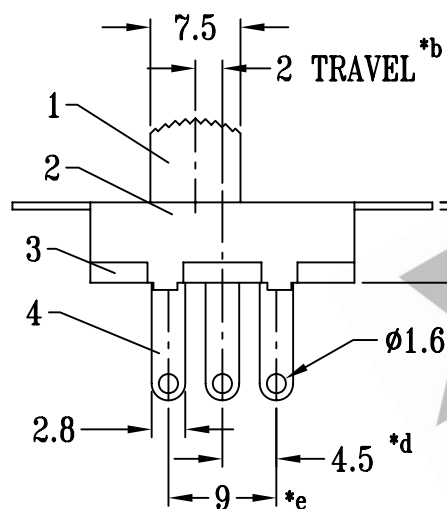

P.C.B LAYOUT

注:带"*"表示关键尺寸(8个)

				TOLERANCE UNLESS SPECIFIED	SHENZHEN XIEJIA ELECTRONICS CO.,LTD.					
8					ISSUE	DATE	DESCRIPTIONS OF REVISION		APPD.	
7	STEEL BALL	STEEL	2	NATURAL						
6	CONTACT CLIP	BRASS STRIP	1	Ag PLATED	WITHIN: 1.5±0.1mm					
5	SPRING	STEEL WIRE	3	TEMPER	OVER : 1.5±0.2mm					
4	TERMINAL	COPPER STRIP	3	Ag PLATED OVER Ni PLATED	TITLE : VERTICAL SLIDE SWITCH		UNIT : mm	DRWG NO.: XJ-DR-SS13D31-00		
3	TERMINAL BASE	PHENOLIC PLATE	1	BLACK	MODEL: SS-13D31		SCALE: 3:2	DWN.	ZHOUYU	2005-3-20
2	FRAME	STEEL STRIP	1	ZINC PLATED	ALL MATERIALS MUST BE COMPLIANT TO ROHS			CHK'D	FANGYING	2005-3-20
1	KNOB	PC	1	BLACK				APPD.	KANGXINAN	2005-3-20
NO.	PARTS	MATERIALS	Q'TY	FINISH						